

## **V-PELD221W Protective Cover for VIP-LD221W LCD Display Speaker with Flashers**

### **INTRODUCTION**

The V-PELD221W Protective Cover is an optional accessory for the Valcom VIP-LD221W LCD Display Speaker with Flashers, designed to provide a protective barrier in front of the Display Speaker without affecting the visibility of the Display.

The Protective Cover is constructed of durable, ¼" (nominal) clear polycarbonate plastic.

### **INSTALLATION**

Three adhesive-backed rubber pads are provided to prevent the Protective Cover from contacting the LCD panel. Before mounting the Cover to the VIP-LD221W, remove the paper strip on the adhesive side and apply the pads to the front of the metal housing of the VIP-LD221W in the positions shown in Figure 1 (one top-center, one each on either side of the Valcom logo).

The Protective Cover mounting brackets are attached to the VIP-LD221W using existing screws in the case. Remove the two screws on each end of the Display and use them to attach the Protective Cover brackets to the Display.

The Protective Cover is shipped with plastic film covering each side to protect it from scratches. Remove this film and mount the Protective Cover to the brackets on the V-PELD221W using four #8-32 screws provided. Note the speaker cutouts are located at the top of the Display.

See Figure 1.

### **TECHNICAL ASSISTANCE**

Assistance in troubleshooting is available from the factory. Call (540) 563-2000 for Technical Support or visit our website at <https://www.valcom.com>.

Valcom equipment is not field repairable. Valcom, Inc. maintains service facilities in Roanoke, VA. Should repairs be necessary, attach a tag to the unit clearly stating company name, address, phone number, contact person, and the nature of the problem. Send the unit to:

**Repair and Return Dept.  
Valcom, Inc.  
5614 Hollins Road  
Roanoke, VA 24019-5056**

### **WARRANTY**

Warranty information can be found on our website at [www.valcom.com/warranty](http://www.valcom.com/warranty).

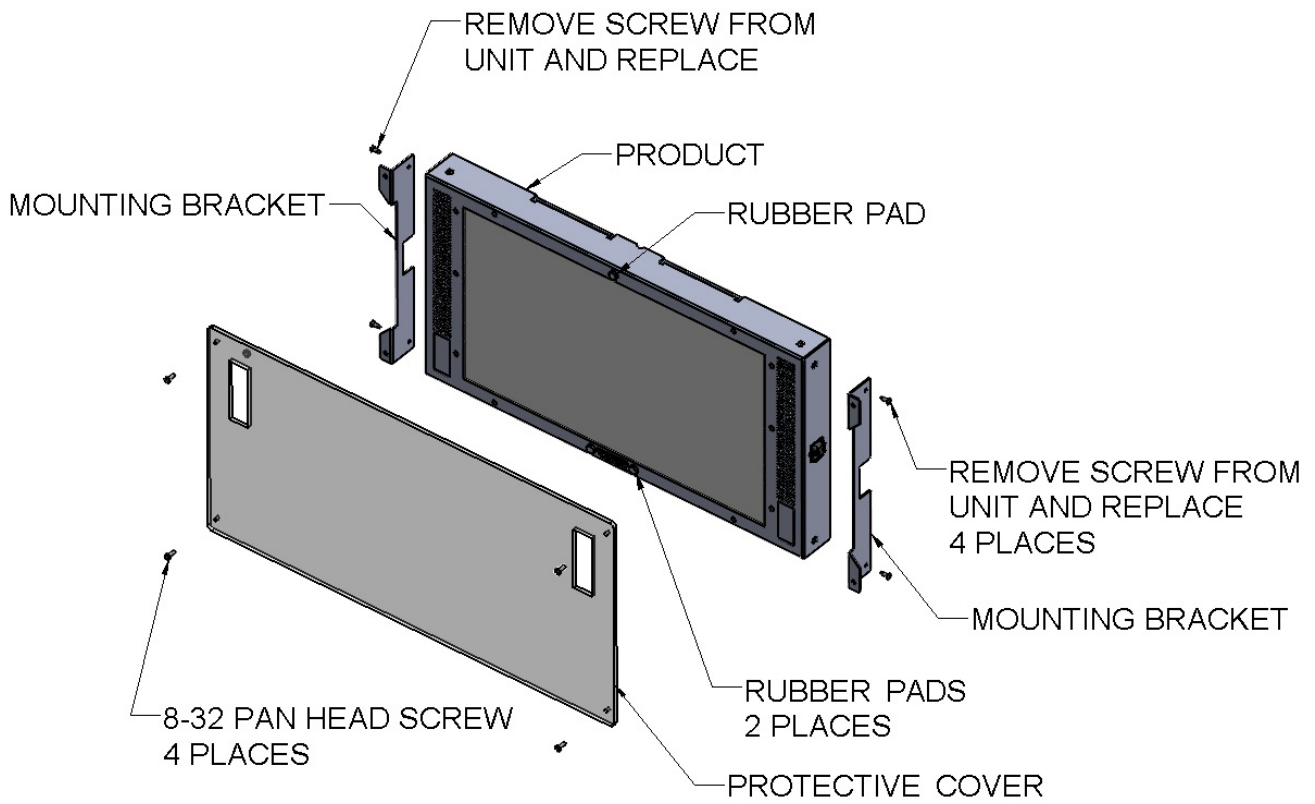

**Figure 1. Protective Cover Assembly**