

VRCPA

RingCentral® Page Adapter

INTRODUCTION

The VRCPA RingCentral® Page Adapter is designed to provide access to paging systems from the RingCentral cloud phone system.



SPECIFICATIONS

Access Methods

- RingCentral system
- Standard telephone (failover)

Electrical Specifications

FXO Input

Ring Detect Voltage 13.5V Min
REN 0.2

FXS Input

DC Open Circuit Voltage -48V Nominal
DC Feed Circuit 45mA Max
DC Differential Output Resistance 160-640 Ohms

Ringing Amplitude (nominal, open circuit) 108V peak
Ring Frequency 20Hz

Audio Sense Release: Programmable
0-600 Seconds
Time Out Release: Programmable
0-3600 Seconds

Talkback Page Out (FXO Output)

Impedance: 600 Ohms
Page Level Output: -10dBm Nominal

One Way Page Out

Impedance: Min. 8 Ohms
Page Level: -10dBm to 0dBm
Music Level: -17dBm to 0dBm
Music Input Impedance: 10k Ohms
-23dBm to 0dBm

Answer Verification Tone: User Programmable
Form A Contacts: 24VDC, 1.0 Amps

Environment

Temperature: 0 to +50°C
Humidity: 0 to 80% (non-precipitating)

Features

- Use with RingCentral cloud phone system
- Use with Valcom multi-zone page control unit with FXS or analog station ports (DTMF signaling only)
- Use with Valcom handsfree page units for talkback paging
- Use with Valcom IP endpoints
- Multiple units may be connected for multi-zone paging with all call behind a PABX
- Background music, stereo or mono input; music mutes during page
- Volume controls for background music and tones
- Security code option to restrict page access
- Store & Play feedback eliminator option
- Multiple disconnect options
- Page verification tone
- Customizable Page alert tone
- Drive up to 150 one-way amplified speakers on 8 Ohm output (one-way output)
- Web interface for programming extended functions
- SIP expanded to 4 extensions, with Night Ring and Store & Play on all lines
- 24 Volt DC Power supply included

Dimensions/Weight

Single unit:

- 9.25" W x 10.12" D x 1.72" H
(23.49cm W x 25.70cm D x 4.36cm H)
- Weight 2.5 lbs (1.134 kgs)
- **Two units mounted for 19" Rack:**
- 19.0" W x 10.12" D x 1.72" H
(48.26cm W x 25.70cm D x 4.36cm H)
- Weight 5.1 lbs (2.313 kg)

These products are intended for use with a UL Listed power source marked "Class 2" or "LPS" rated 24VDC. All interconnected ITE are intended for intra-building.

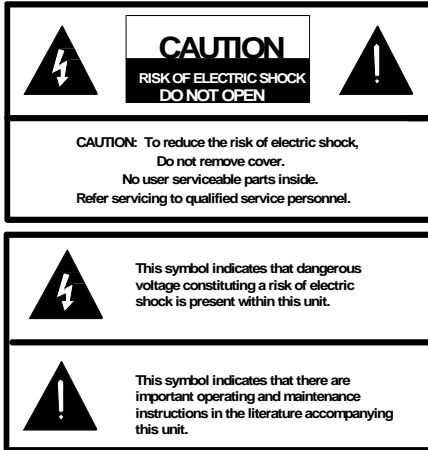

**IMPORTANT SAFETY INFORMATION
CONSIGNES DE SÉCURITÉ IMPORTANTES**

1. Read these instructions.
Lisez ces instructions.
2. Keep these instructions.
Conservez ces instructions.
3. Heed all warnings.
Respectez tous les avertissements.
4. Follow all instructions.
Suivez toutes les instructions.
5. Do not use this apparatus near water.
Ne pas utiliser cet appareil près de l'eau.
6. Clean only with dry cloth.
Nettoyer avec un chiffon sec.
7. Do not block any ventilation openings. Install in accordance with the manufacturer's instructions.
Ne pas bloquer les ouvertures de ventilation. Installer conformément aux instructions du fabricant.
8. Do not install near any heat sources such as radiators, heat registers, stoves or other apparatus (including amplifiers) that produce heat.
Ne pas installer à proximité de sources de chaleur telles que radiateurs, registres de chaleur, poêles ou autres appareils (y compris les amplificateurs) produisant de la chaleur.
9. Do not defeat the safety purpose of the polarized or grounding-type plug. A polarized plug has two blades with one wider than the other. A grounding type plug has two blades and a third grounding prong. The wide blade and the third prong are provided for your safety. If the provided plug does not fit into your outlet consult an electrician for replacement of the obsolete outlet.
Ne pas contourner le dispositif de sécurité de la fiche polarisée ou de mise à la terre. Une fiche polarisée possède deux lames dont une plus large que l'autre. Une fiche de terre à deux lames et une troisième broche de mise à la terre. La lame large et la troisième broche sont fournies pour votre sécurité. Si la fiche fournie ne rentre pas dans votre prise, veuillez consulter un électricien pour le remplacement de la prise obsolète.
10. Protect the power cord from being walked on or pinched particularly at plugs, convenience receptacles and the point where they exit from the apparatus.
11. Only use attachments/accessories specified by the manufacturer.
N'utilisez que des fixations / accessoires spécifiés par le fabricant.
12. Use only with the cart, stand, tripod, bracket or table specified by the manufacturer or sold with the apparatus. When a cart is used, use caution when moving the cart/apparatus combination to avoid injury from tip-over.
Utilisez uniquement avec le chariot, stand, trépied, support ou table spécifié par le fabricant ou vendu avec l'appareil. Quand un chariot est utilisé, Soyez prudent lorsque vous déplacez l'ensemble chariot / appareil pour éviter des blessures dues au renversement.
13. Unplug this apparatus during lightning storms or when unused for a long period of time.
Débranchez cet appareil pendant les orages ou lorsqu'il n'est pas utilisé pendant une longue période de temps.
14. Refer all servicing to qualified service personnel. Servicing is required when the apparatus has been damaged in any way. Such as when the power supply cord or plug is damaged, liquid has been spilled, objects have fallen into the apparatus or the apparatus has been exposed to rain or moisture and does not operate normally or has been dropped.
Confiez toute réparation à un personnel qualifié. Une réparation est nécessaire lorsque l'appareil a été endommagé de quelque façon. Par exemple lorsque le cordon d'alimentation ou la fiche est endommagé, du liquide a été renversé, si des objets sont tombés dans l'appareil ou le appareil a été exposé à la pluie ou à l'humidité et ne fonctionne pas normalement ou s'il est tombé.



- Apparatus shall not be exposed to dripping or splashing and no objects filled with liquids, such as vases, shall be placed on the apparatus.
- L'appareil ne doit pas être exposé à des égouttements et éclaboussures et aucun Objet Rempli de liquide, comme vase, ne doit être placé sur l'appareil.

FCC Information

This equipment has been tested and found to comply with the limits for a Class A digital device, pursuant to Part 15 of the FCC Rules. These limits are designed to provide reasonable protection against harmful interference when the equipment is operated in a commercial environment. This equipment generates, uses and can radiate radio frequency energy and if not installed and used in accordance with the instruction manual, may cause harmful interference to radio communications. Operation of this equipment in a residential area may cause harmful interference in which case the user will be required to correct the interference at one's own expense.

General Mounting Information

- A) Elevated Operating Ambient - If installed in a closed or multi-unit rack assembly, the operating ambient temperature of the rack environment may be greater than room ambient. Therefore, consideration should be given to installing the equipment in an environment compatible with the maximum ambient temperature (Tma) specified by the manufacturer.
- B) Reduced Air Flow - Installation of the equipment in a rack should be such that the amount of air flow required for safe operation of the equipment is not compromised.
- C) Mechanical Loading - Mounting of the equipment in the rack should be such that a hazardous condition is not achieved due to uneven mechanical loading.
- D) Circuit Overloading - Consideration should be given to the connection of the equipment to the supply circuit and the effect that overloading of the circuits might have on overcurrent protection and supply wiring. Appropriate consideration of equipment nameplate ratings should be used when addressing this concern.
- E) Reliable Earthing - Reliable earthing of rack-mounted equipment should be maintained. Particular attention should be given to supply connections other than direct connections to the branch circuit (e.g. use of power strips).
- F) Equipment only suitable for mounting at heights less than or equal to 2m (6.56').

Power Requirements

The VRCPA requires 24 Volt DC power. Power may be connected using either the barrel connector or two screw terminals located on the back panel. The recommended power supply is the VP-624D, included with the VRCPA. Other 24vdc power supply providing a minimum of 600 mA may be used if necessary.

Precautionary Designations

- **WARNING-To Reduce The Risk Of Fire Or Electric Shock. Do Not Expose This Apparatus To Rain Or Moisture**
- **AVERTISSEMENT - Afin de réduire les risques d'incendie ou de décharge électrique, évitez d'exposer le système à la pluie ou à l'humidité.**

INSTALLATION

Regulatory Information

This equipment is to be installed only in restricted access areas (dedicated equipment rooms, equipment closets or the like).

When using this equipment, basic safety precautions should always be followed to reduce the risk of fire, electric shock and injury to persons including the following:

1. Never install telephone wiring during a lightning storm.
2. Never install telephone jacks in wet locations unless the jack is specifically designed for wet locations.
3. Never touch uninsulated telephone wires or terminals unless the telephone line has been disconnected at the network interface.
4. Use caution when installing or modifying telephone lines.

Mounting

Wall: Attach the mounting brackets to the VRCPA using the included hardware. Use the wood screws provided to attach the VRCPA to the wall. For surfaces other than wood, use hardware appropriate for the surface (not included). See Figure 1.

Rack: The VRCPA may be rack mounted either as a single unit or as two VRCPA units joined together and installed into a 1U rack slot.

For a single unit, attach one small end bracket to one end of the VRCPA and attach the long bracket to the other side of the VRCPA, then mount into an available rack slot as shown in Figure 2. The long or short bracket may be connected on either end.

For mounting two VRCPA units in a single 1U slot, use Figure 3 as a guide. Attach the interlock brackets and small end mounting brackets to each of the VRCPA units, then mount the combined units into an available rack slot.

Connections

Front Panel

The front panel of the VRCPA has the following controls:

- **Monitor** is a 3.5 mm headset jack for monitoring audio being sent to the output ports.
- **Music** volume control adjusts the output level of the background music to the output port.
- **Tone** volume control adjusts the output level of the page pre-announce tone.
- **Status** LED indicates the operating status of the VRCPA.
 - **Green** indicates powered on and idle
 - **Amber** indicates Page in progress
 - **Red** during the bootup sequence, or to indicate a fault condition
- **Ethernet** is an RJ45 ethernet connection with two status LEDs:

- **Green:** (Link) Indicates Ethernet connection when illuminated.
- **Yellow:** (Activity) Indicator flashes to indicate network activity

Rear Panel

The rear panel of the VRCPA is located behind a removable cover and contains the signal connections.

- **Power** connections are provided with two options. Either the barrel connector or the two screw terminals may be used.
- **Function Settings** is a 6-position DIP switch for setting feature options. The settings are described more fully in this document.
- **Music In** provides two methods for connecting a background music source. Either the stereo RCA jacks or the screw terminals may be used. Stereo signals on the RCA jacks will be combined to mono.
- **One Way Page Out** is the audio output for speakers or amplifiers. The background music and paging audio will output on these two terminals.
- **Relay** is a normally open relay connection which closes when a page is active.
- **All Call Audio** is the audio input connection for accepting audio from other VRCPA controllers when the controllers are used in a multiple-zone arrangement.
- **Talkback Page Out** is the output connection providing FXO signaling to establish connection to a page controller. This connection is typically used with multi-zone page controllers.
- **All Call Control** is used in conjunction with the All Call Audio connection when used with other VRCPA controllers in a multiple-zone arrangement.
- **Page Inputs**
 - **FXS** provides FXS signaling. This is used with a single line telephone or PBX loop start trunk port. Dial tone is provided from this port. This port is active when SW 6 is ON.
 - **FXO** provides FXO signaling. This is used with an FXS Station Port and will answer inbound calls signaled by ring voltage. This port is active when SW 6 is OFF.

Setup

Basic options to set the Input and Output ports on the VRCPA must be done using the DIP switch options noted in this document. Other basic settings can also be accomplished using the DIP switches. Additional programming can be done using a touch-tone phone connected to the FXS port or through the web interface of the VRCPA. Separate documentation on using these features is available on the Valcom web site.

Function Settings DIP Switch

Output Port Selection (SW 1)

Two output connections are available on the VRCPA. The Talkback Page Out connection provides FXO (loop-start trunk) signaling. The One Way Page Out connection provides a standard tip/ring audio output. The default level of the One Way Page Out is -10dBm, but can be changed in software to +2.2 dBm for applications that require the higher output level.

SW 1	Talkback Page Out	One Way Page Out
ON	Enabled	Disabled
OFF	Disabled	Enabled

Silence Timeout Selection (SW 2 & 3)

Silence Timeout indicates how many seconds the VRCPA will stay active after the audio input has stopped. This can be used to disconnect a call after the caller has stopped speaking. Three values are available with the switch settings; additional options are available in software programming.

SW 2	SW 3	Timeout
OFF	OFF	8 Seconds
OFF	ON	4 Seconds
ON	OFF	2 Seconds
ON	ON	Software control (default: no timeout)

Absolute Timeout Selection (SW 4 & 5)

Absolute Timeout indicates how many seconds the VRCPA will stay active for any caller. When the timeout setting expires, the call is disconnected. Three values are available with the switch settings; additional options are available in software programming.

SW 4	SW 5	Timeout
OFF	OFF	128 Seconds
OFF	ON	16 Seconds
ON	OFF	8 Seconds
ON	ON	Software control (default: no timeout)

Input Port Selection (SW 6)

Input Port selects which of the Page Input RJ11 jacks is active. The ports are labeled FXO and FXS to indicate the type of signaling provided. The FXS port detects off-hook condition and provides dial tone to the circuit. The FXS port can be used with a standard phone or loop-start trunk port. The FXO port is a loop-start trunk port and can be used with a Station Port or FXS on a PBX.

SW 6	Page Input FXS	Page Input FXO
ON	Enabled	Disabled
OFF	Disabled	Enabled

**** The VRCPA must be power cycled for any DIP switch changes to take effect. ****

TECHNICAL ASSISTANCE

When trouble is reported, verify that power is being supplied to the unit and there are no broken connections. If a spare unit is available, continue to troubleshoot by substituting the spare unit for the suspected defective unit.

Assistance in troubleshooting is available from the factory. When calling, you should have a VOM, several clip leads, a telephone test set available and call from the job site.

Call (540) 563-2000 or visit our website at <http://www.valcom.com>.

The VRCPA is not field repairable. Valcom, Inc. maintains service facilities in Roanoke, VA. Should repairs be necessary, attach the company name, address, phone number, contact person and the nature of the problem. Send the unit to:

Valcom, Inc.
Repair and Return Dept.
5614 Hollins Road
Roanoke, VA 24019-5056

WARRANTY

Warranty information may be found on our website at www.valcom.com/warranty

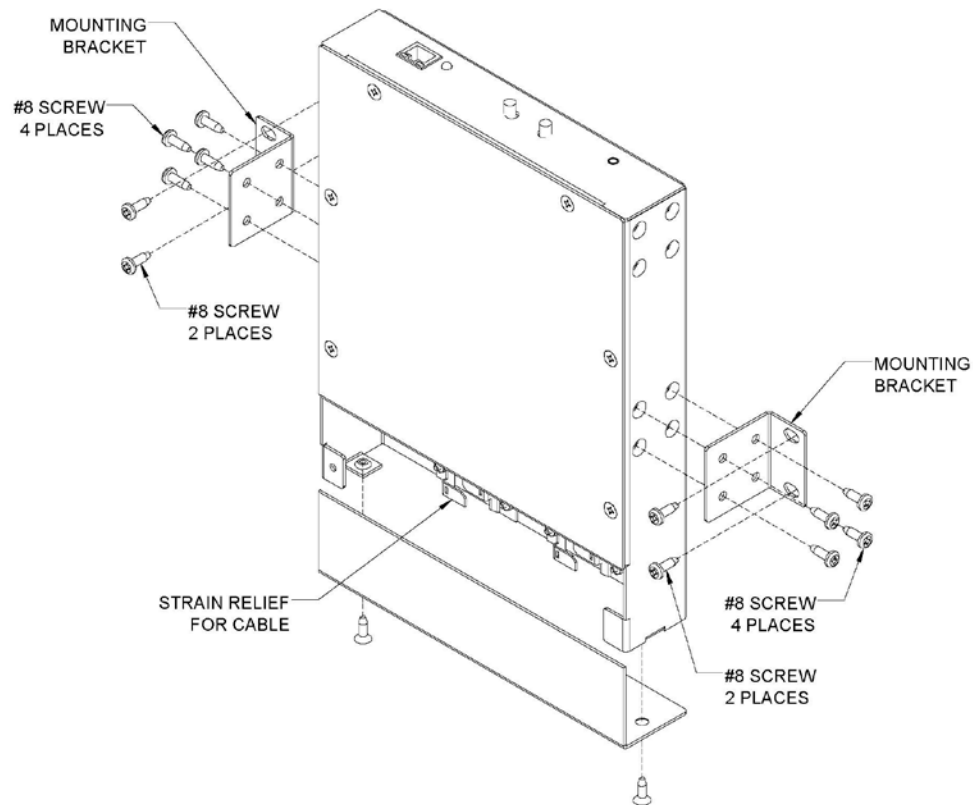

Figure 1. Wall Mounting

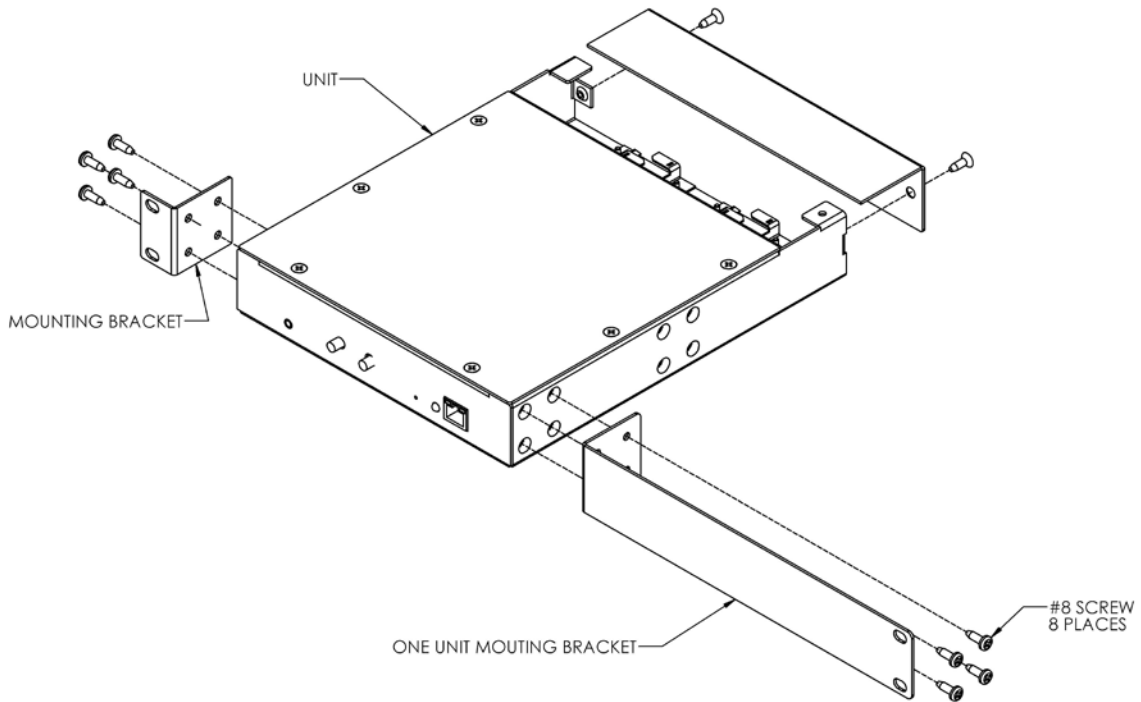

Figure 2. Single Unit Rack Mount

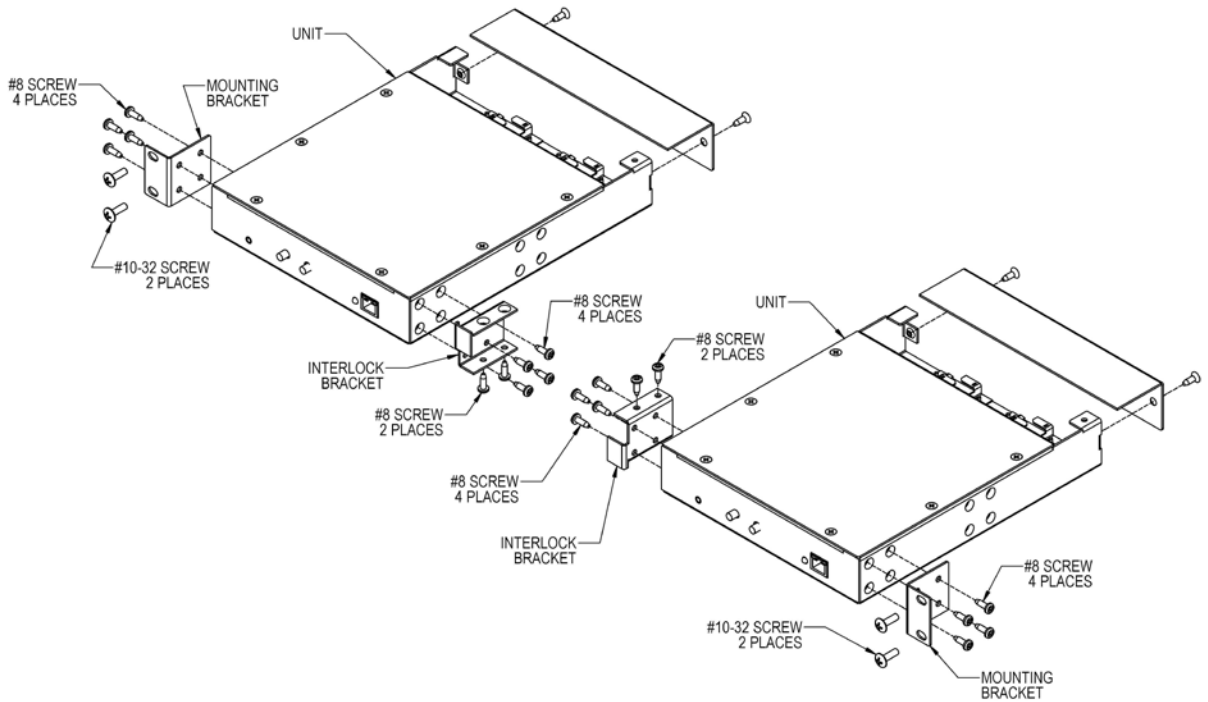
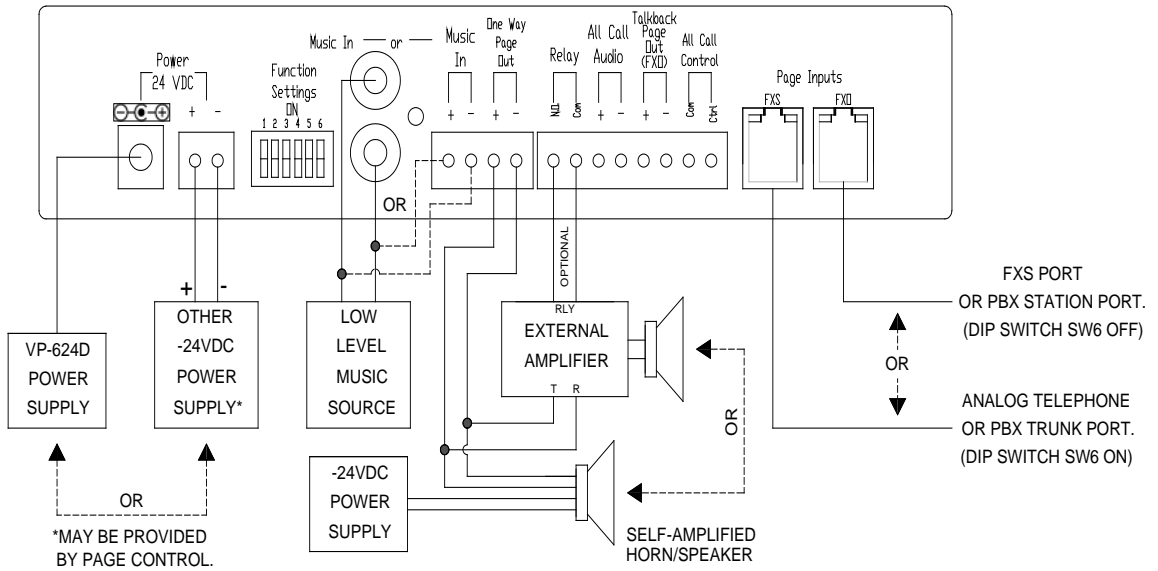

Figure 3. Mounting Two Joined Units

CONNECTIONS TO SELF-AMPLIFIED SPEAKERS OR EXTERNAL AMPLIFIER



CONNECTIONS TO MULTI-ZONE CONTROLLERS

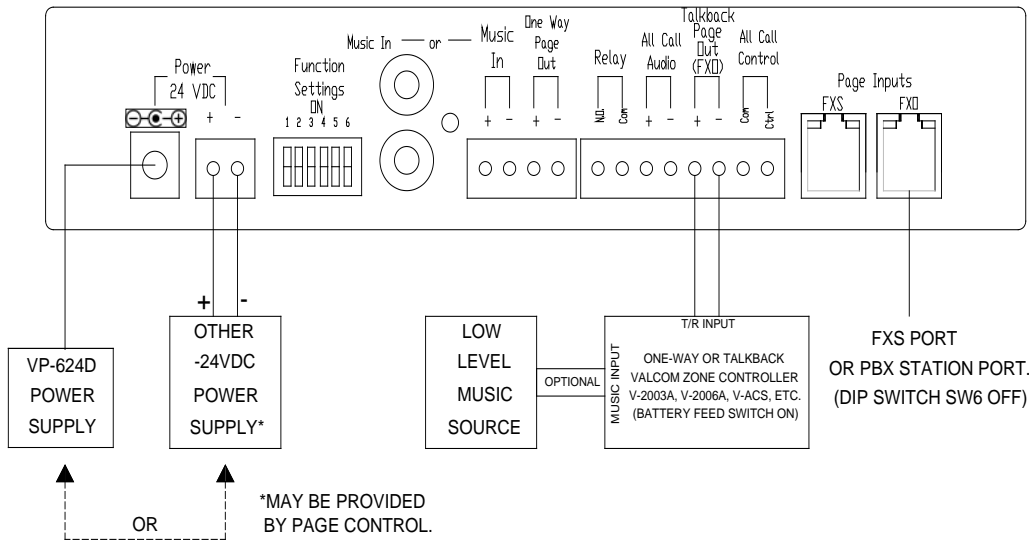

Figure 4. Connections