

AXIS C15 Series

AXIS C1510 Network Pendant Speaker

AXIS C1511 Network Pendant Speaker

Repainting Instructions

AXIS C15 Series

Impact on warranty

Impact on warranty

This product is approved for repaint by Axis, provided that you follow the instructions in this document and at axis.com/warranty-implication-when-repainting.

Risks with repainting

There are several risks when disassembling or assembling an Axis product. There is always a certain yield loss during assembly. Training of operators and the use of correct tools mediates some of the problems but they can never be fully avoided. Some of the risks include:

ESD Damage – Always handle the product in an ESD safe environment. Even if precautions are taken there is always a risk of ESD damage. The damage can remain undetected and cause problems during the lifetime of the equipment.

Dust contamination – Opening a camera may expose the lens and sensor to dust or paint. Dust will affect the optical performance. Lenses need to be disassembled in a dust-free environment, preferably a cleanroom.

Paint overspray – Masking the different components of the equipment is critical. Failure to mask sensitive areas can cause problems with assembling the equipment. Any areas that are not painted at factory or have a different surface treatment than the rest of the parts (threads, ground and electrical contact surfaces) must also be masked to ensure function.

AXIS C15 Series

Repaint the product

Repaint the product

Preparations

- If applicable, disassemble the device according to the instructions in this document.
- Clean all parts that will be repainted thoroughly to remove grease, dust, or oil.
- To ensure reassembly and functionality of the product, mask any openings (for example for screws, LED indicators, or microphones) before you paint.
- To avoid unwanted reflections, mask the inside of the weathershield before you paint.

Pretreatment of parts

Depending on the part material and type of paint applied at factory, different pretreatment should be done for the new paint to adhere as well as possible. Clean the parts properly to remove oil, grease and dust.

Powder coated parts – Use a primer. Alternatively, remove the original powder coating down to the base material, using fine sandpaper, and clean the parts before painting.

Anodised and chromated parts – Use a primer.

Uncoated stainless steel – No special pretreatment is needed, but make sure that the surface is clean before painting.

Plastic – Use a primer.

AXIS C15 Series

Repaint the product

Disassembly

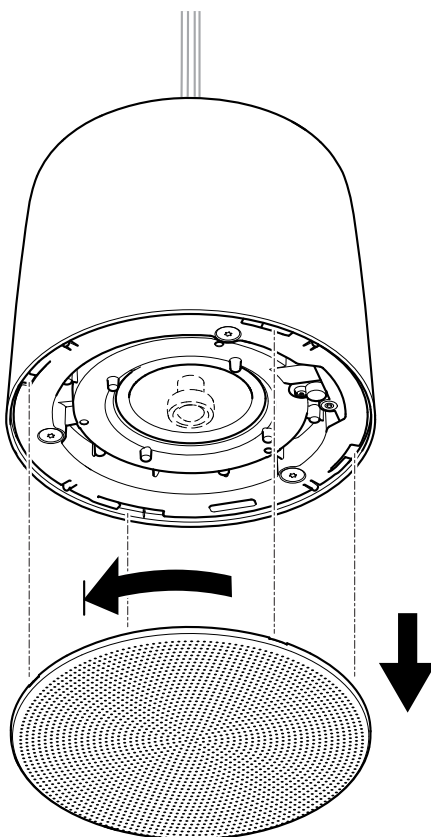

1. Remove the mesh.

AXIS C15 Series

Repaint the product

Repainting

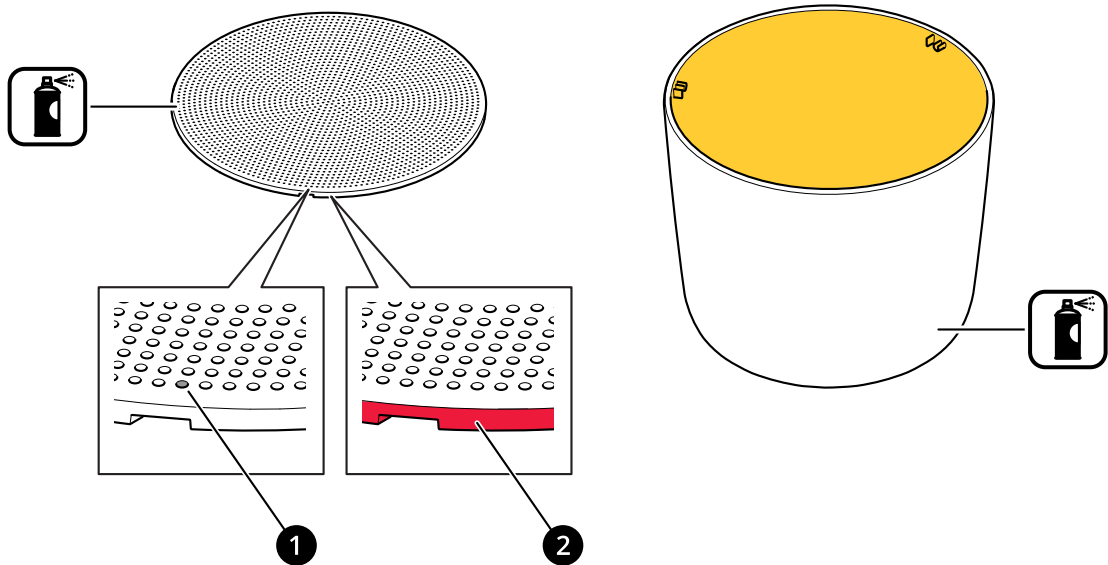

- 1 Mesh holes
- 2 Mesh edge

1. Make sure all necessary preparations of the cover have been made, see *Preparations on page 3*.
2. Apply a thin and even layer of spray paint according to the instructions of the paint manufacturer. The paint should cover the visible parts, including the edge of the mesh (2).

CAUTION

Make sure the paint does not clog the holes of the mesh (1), as that might impede the sound from the speaker.

3. Let the paint dry.
4. To get a better coverage and clearer color, apply a second layer of spray paint.

Reassembly

1. When the paint is dry, reassemble the product.

